

Recessed LED panel

Recessed LED panel UGR<19. Elegant and timeless design with slim metal frame of only 8.5mm depth. Opal diffuser with fully homogenous illumination. Even surface UGR<19: gentle, soft and glare-free lighting for office applications. Tool-free installation (piano key terminal for up to 2.5 mm² wires). External connector box enabling loop-in loop-out wiring. Flicker-free. Replaces conventional luminaires with 4 x 18 W T8 and offers up to 60 % energy saving. Suitable for lay-in installation, suspension and surface mounting. 3h emergency lighting. THD≤20%.

Frame: Aluminium

Diffuser: TpB rated PET-diffuser, opal

Light guide plate: PS

Backplate: metal, white (RAL 9003)

Weight: 3.31 kg



TE_ANNA_F_600_INT.jpg

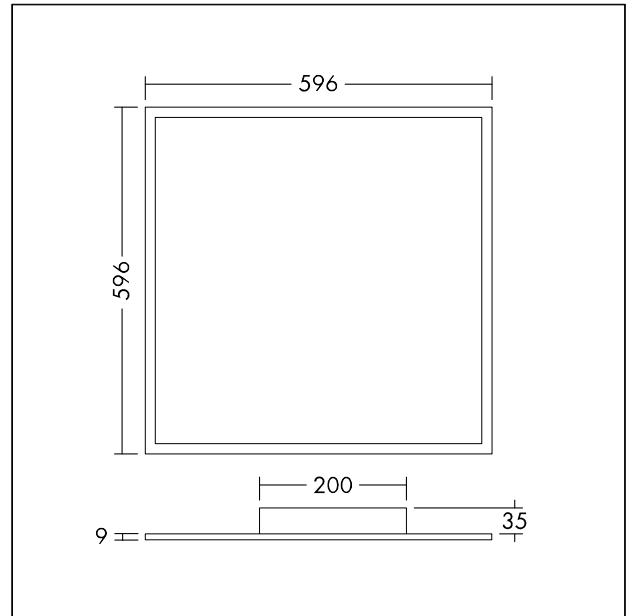

TE_ANNA_M_596_E3.wmf

Light Distribution

Emergency

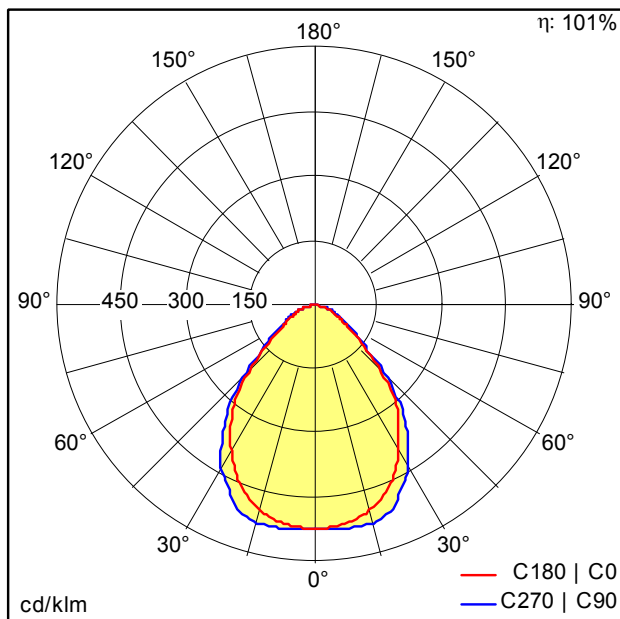

TE_ANNA_LED_Q596_3500_840_E3e.idt

- Light Source: LED
- Luminaire luminous flux*: 295 lm
- Luminaire efficacy*: 98 lm/W
- Colour Rendering Index min.: 80
- Chromaticity tolerance (initial MacAdam)*: 4
- Rated median useful life*: 50000h L70 at 25°C
- Ballast: 1x LED_Con
- Luminaire input power*: 3 W
- Dimming: Fixed output